

# Air-Pak Dryer Systems

## Protect compressed air lines from oil, water and particulate

Easy to maintain, the *AIR-PAK* is a compact heatless desiccant air dryer which delivers high quality compressed air capable of achieving superior pressure dew points  $-40^{\circ}\text{F}$  or lower. Use *AIR-PAK* when precision work requires high quality air.

## Reduce energy and operating costs with the *AIR-PAK*.

Contaminated compressed air lines drags down productivity, raises operating costs, and increases maintenance requirements.

### *AIR-PAK* benefits include:

- Typically requires less than 10% regeneration
- Electrical usage requires only .68 ampere operation
- Extends service life of pneumatic driven devices
- Avoid expensive replacement or downtime to pneumatic equipment
- Desiccant cartridges spin on/off for quick service
- Internal filtration protects desiccant bed and downstream components
- Modular design allows for quick, easy and flexible expansion

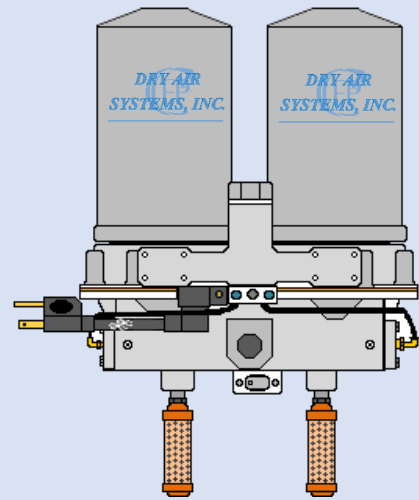

### How It Works

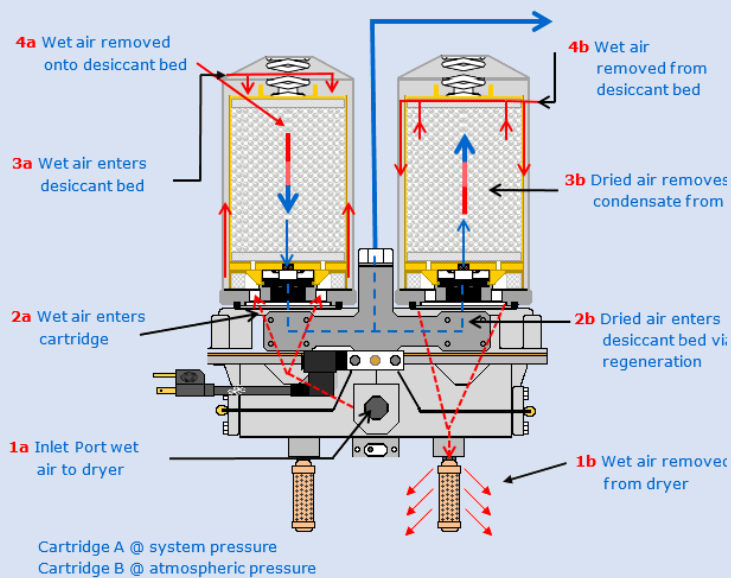

Listed are types of operations that significantly reduced operating costs

- Vehicle wash stations
- Packing equipment
- Lab measurement equipment
- Paint/foam spraying
- Sand/shot blasting
- Air tools
- Drilling equipment
- Railcar braking systems & Loci's
- Mining car dump stations
- Dust collection systems
- Baghouse equipment
- Bottling equipment
- Plasma cutting
- Drag line shovels
- Batch mixing
- Rail maintenance equipment



Office: 314.344.1114

Fax: 314.344.0677

2655 Metro Blvd. Maryland Heights, MO.

[www.dry-air-systems.com](http://www.dry-air-systems.com)

# Air-Pak Dryer Systems

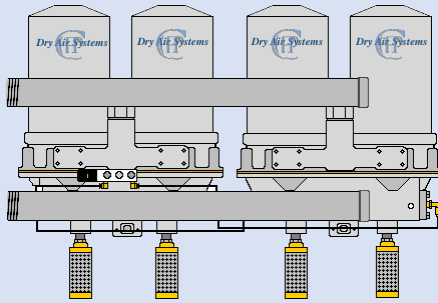

Max 80 CFM

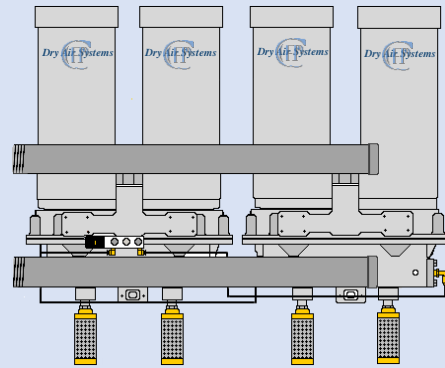

Max 120 CFM

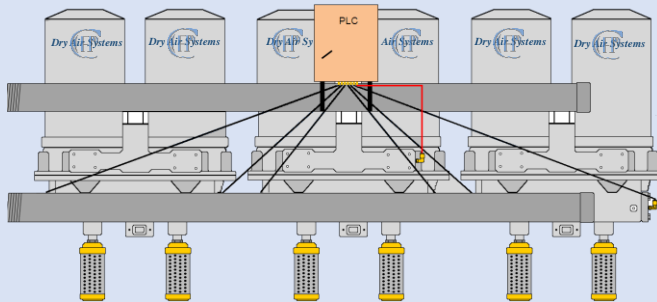

Max 200 CFM

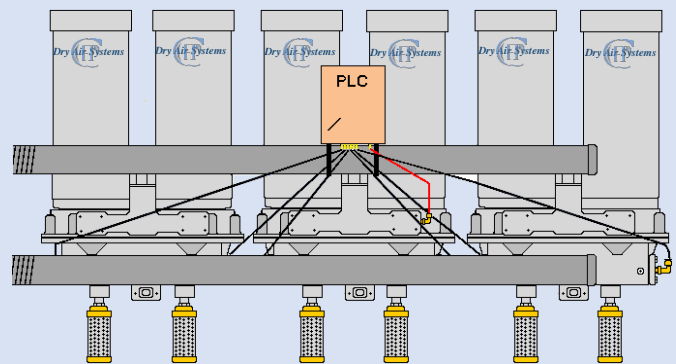

Max 300 CFM

## Air-Pak Dryer w/ 4 LB. Cartridges

Compressor HP	Max CFM	110 VAC Standard	Number of Cartridges	Part Number
5	20	MLT	2	JP2A
7.5	27	MLT	2	JP2A
10	40	MLT	2	JP2B
15	60	MLT	4	JP3B
20	80	MLT	4	JP3B
30	120	PLC	4	JP4C
50	200	PLC	6	JP6C
60	240	PLC	8	JP8C
75	300	PLC	10	JP10C
100	400	PLC	12	JP12C
150	600	PLC	18	JP18C
	800	PLC	24	JP24C

MLT = Micro Logic Timer

PLC = Programed Logic Control

Filtration: JP Series dryers .3 micron,

Custom Air-Pak Systems Available

Heaters - Optional 75Watt 120 VAC, 12, or 24 VDC

Divide number of cartridges by 2 e.g., JPC-6 requires 3 heaters

All dryers assembled, tested and include manifolds and mounting

## Air-Pak Dryer w/ 8 LB. Cartridges

Compressor HP	Max CFM	110 VAC Standard	Number of Cartridges	Part Number
10	40	MLT	2	JP2B-L
15	60	MLT	2	JP2B-L
20	120	MLT	4	JP3C-L
30	180	PLC	4	JP4C-L
50	300	PLC	6	JP6C-L
75	420	PLC	8	JP8C-L
100	480	PLC	10	JP10C-L
125	600	PLC	12	JP12C-L
150	960	PLC	18	JP18C-L
	1320	PLC	24	JP24C-L

MLT - Micro Logic Timer

PLC - Programed Logic Control

Filtration: - JP Series dryers .3 micron

Custom Air-Pak Systems Available

Heaters - Optional 75Watt 120 VAC, 12, or 24 VDC

Divide number of cartridges by 2 e.g., JPC-6 requires 3 heaters

All dryers assembled, tested and include manifolds and mounting



Office: 314.344.1114

Fax: 314.344.0677

2655 Metro Blvd. Maryland Heights, MO.

www.dry-air-systems.com